

IDENTIFYING CCI COMPRESSORS

The metal nameplate located at the top front of the compressor serves as a means of identification. The location permits viewing the nameplate with the clutch installed.

Data inscribed on the nameplate includes the serial number, combination model/part number, date of manufacture and type of refrigerant.

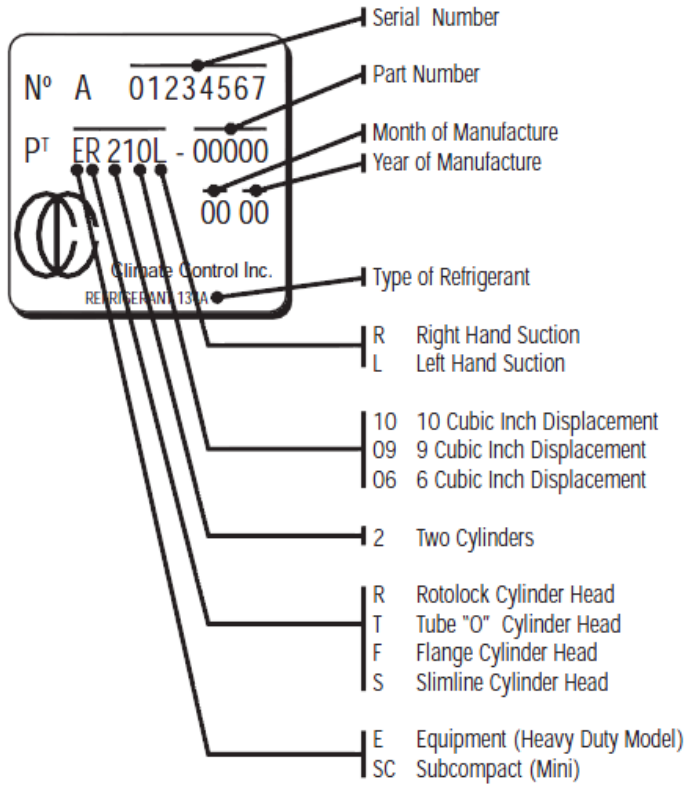

CCI HEAD TYPES

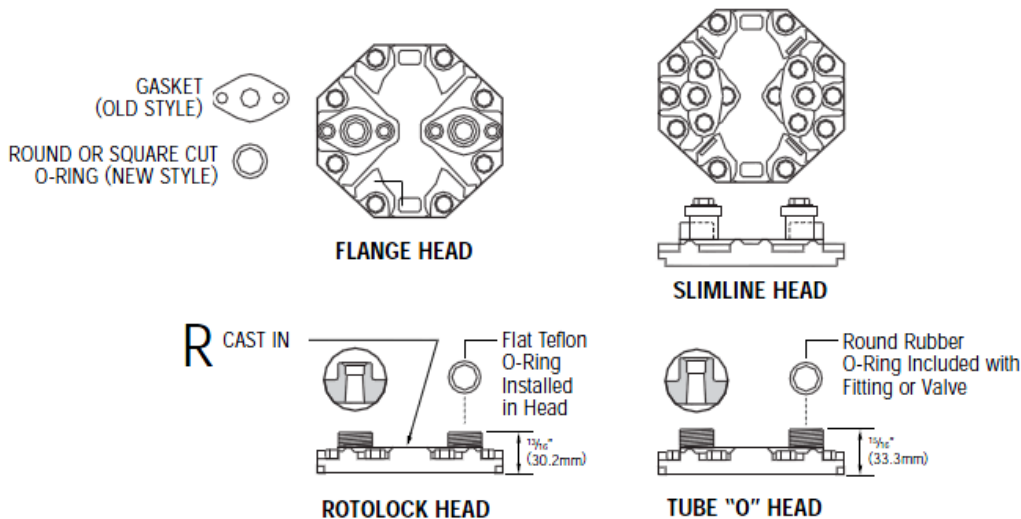

Information taken from RED DOT Corporation 2006 Heavy Duty Heating and Air Conditioning manual page 181.